

# Hi-WALL

## STANDARD DRAWINGS 2017



Hi-WALL

# Hi-Wall Standard Drawings Register 2017

<u>DRG. No.</u>	<u>REV.</u>	<u>DESCRIPTION</u>
HW-001	<input type="checkbox"/>	Stud Fabrication Detail
HW-002	<input type="checkbox"/>	Header Fabrication Detail
HW-003	<input type="checkbox"/>	Deflection Header Fabrication Detail
HW-004	<input type="checkbox"/>	Zed Hanger Fabrication Detail
HW-005	<input type="checkbox"/>	Flat Brace Fabrication Detail
HW-006	<input type="checkbox"/>	Cleat Fabrication Detail
HW-007	<input type="checkbox"/>	Fixings Order Form
HW-SET	<input type="checkbox"/>	Hi-WALL Standard Drawings - Complete Set

OVERALL LENGTH

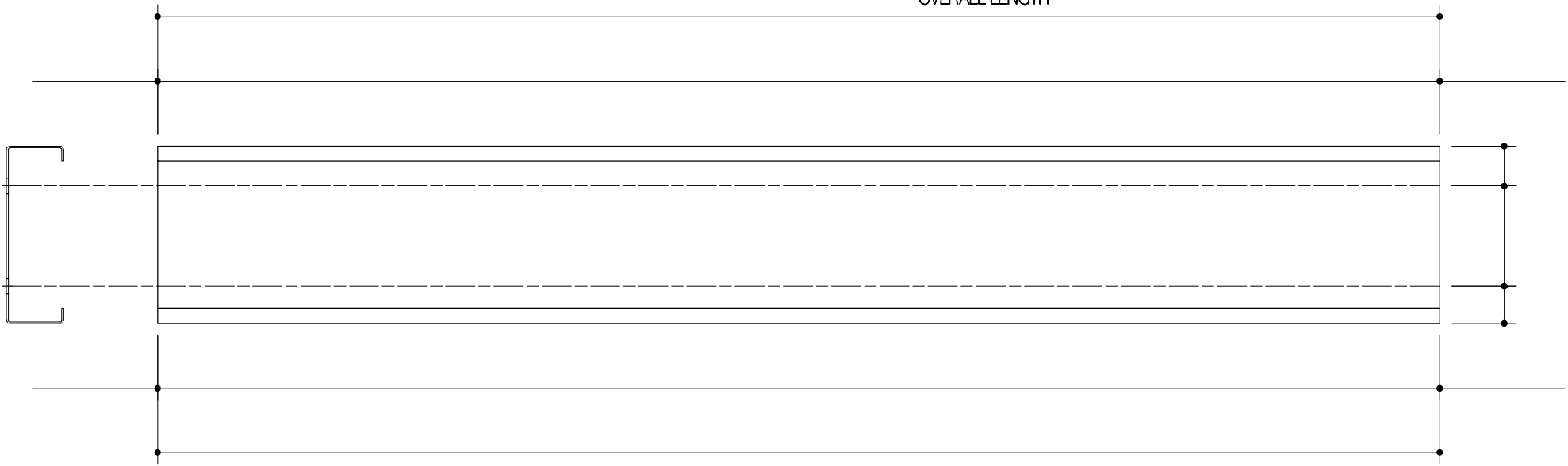

SECTION REF	DIMENSIONS		
	A	B	C
S 70 50	25	70	50
S 70 66	33	70	66
S 100 50	25	100	50
S 100 66	33	100	66
S 150 50	25	150	50
S 150 66	33	150	66
S 200 66	33	200	66
S 225 66	33	225	66
S 255 80	40	255	80
S 285 75	37.5	285	75
S 285 80	40	285	80
S 305 75	37.5	305	75

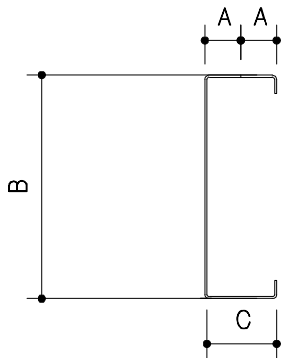

MARK:	No. RQD AS DRAWN:
MARK:	No. RQD OPP HAND:

Hi-SPAN Ltd.  
 Ayton Road, Wymondham  
 Norwich, Norfolk, NR18 0RD  
 Telephone: 01953 603081  
 Fax: 01953 607842  
 Email: technical@hi-span.com  
 Web: www.hi-span.com



DRG TITLE: STUD FABRICATION DETAIL

NOTES: 1: ALL HOLES 18 DIA. U.N.O  
 2: COUNTERFORMED HOLES IN WEB MARKED   
 3: COUNTERFORMED HOLES IN FLG MARKED

DRAWN BY:	DATE:
CHK'D BY:	DATE:
DRG No: HW-001	Rev:
ISSUE: 1st ISSUE	
SECTION REF:	

CUSTOMER:
ORDER REF:
SKETCH No:
HI-SPAN JOB No:

OVERALL LENGTH

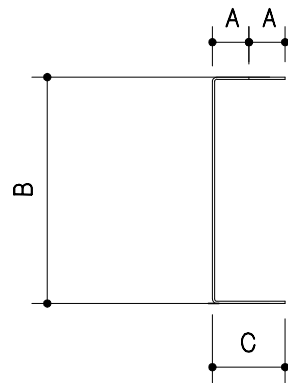
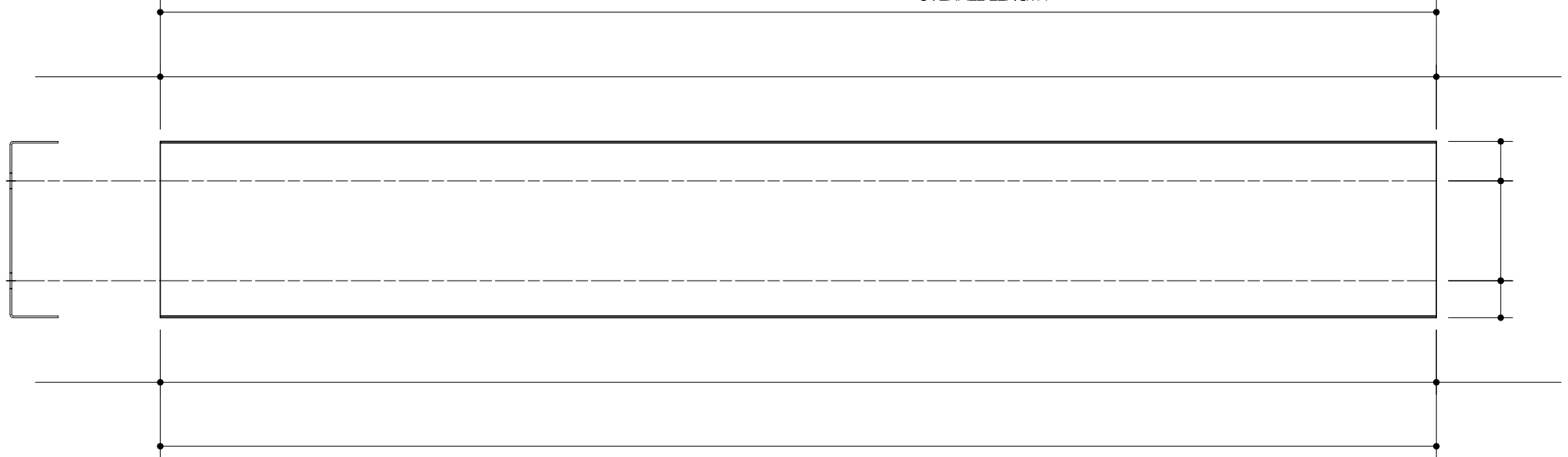

SECTION REF	DIMENSIONS		
	A	B	C
H 75 35	17.5	75	35
H 75 57	28.5	75	57
H 75 65	32.5	75	65
H 105 42	21	105	42
H 105 44	22	105	44
H 105 65	32.5	105	65
H 155 40	20	155	40
H 155 62	31	155	62
H 205 40	20	205	40

SECTION REF	DIMENSIONS		
	A	B	C
H 205 70	35	205	70
H 230 40	20	230	40
H 230 65	32.5	230	65
H 260 40	20	260	40
H 260 70	35	260	70
H 270 40	20	270	40
H 290 70	35	290	70
H 310 40	20	310	40
H 310 72	36	310	72



MARK:	No. RQD AS DRAWN:
MARK:	No. RQD OPP HAND:



Hi-SPAN Ltd.  
 Ayton Road, Wymondham  
 Norwich, Norfolk, NR18 0RD  
 Telephone: 01953 603081  
 Fax: 01953 607842  
 Email: technical@hi-span.com  
 Web: www.hi-span.com



DRG TITLE: HEADER FABRICATION DETAIL

- NOTES:
- 1: ALL HOLES 18 DIA. U.N.O
  - 2: COUNTERFORMED HOLES IN WEB MARKED 
  - 3: COUNTERFORMED HOLES IN FLG MARKED 

DRAWN BY: DATE:

CHK'D BY: DATE:

DRG No: HW-002 Rev: ISSUE: 1st ISSUE

SECTION REF:

CUSTOMER:

ORDER REF:

SKETCH No:

HI-SPAN JOB No:

OVERALL LENGTH

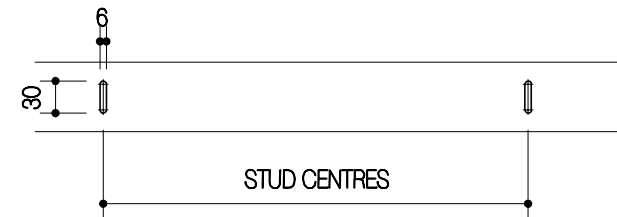

6mm x 30mm SLOT IN FLANGE OF HEADER

SECTION REF	DIMENSIONS		
	A	B	C
DH 75 65	32.5	75	65
DH 105 65	32.5	105	65
DH 155 62	31	155	62
DH 205 70	35	205	70
DH 230 65	32.5	230	65
DH 260 70	35	260	70
DH 290 70	35	290	70
DH 310 72	36	310	72

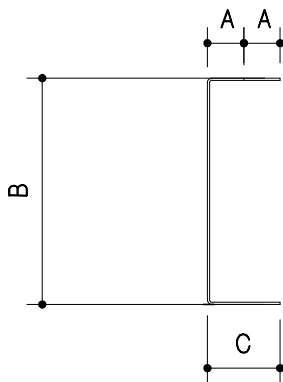



MARK:	No. RQD AS DRAWN:
MARK:	No. RQD OPP HAND:



Hi-SPAN Ltd.  
 Ayton Road, Wymondham  
 Norwich, Norfolk, NR18 0RD  
 Telephone: 01953 603081  
 Fax: 01953 607842  
 Email: technical@hi-span.com  
 Web: www.hi-span.com



DRG TITLE: DEFLECTION HEADER FABRICATION DETAIL

- NOTES:
- 1: ALL HOLES 18 DIA. U.N.O
  - 2: COUNTERFORMED HOLES IN WEB MARKED 
  - 3: COUNTERFORMED HOLES IN FLG MARKED 

DRAWN BY:	DATE:	CUSTOMER:
CHK'D BY:	DATE:	ORDER REF:
DRG No: HW-003	Rev:	ISSUE: 1st ISSUE
SECTION REF:	Hi-SPAN JOB No:	

OVERALL LENGTH

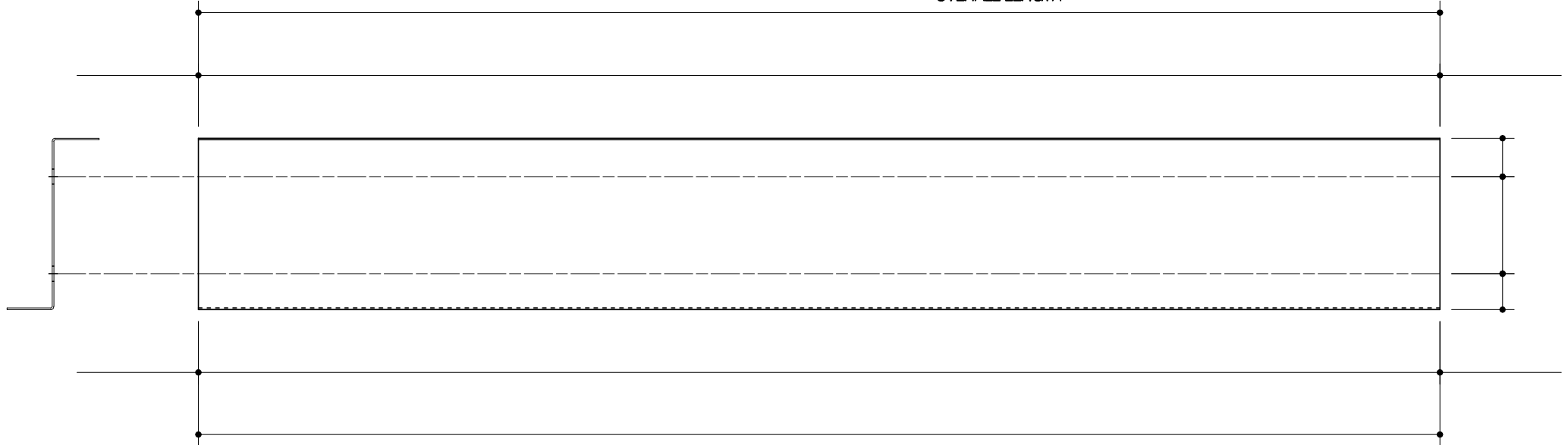

SECTION REF	DIMENSIONS		
	A	B	C
ZH 77	50	77	78
ZH 107	50	107	78
ZH 157	50	157	73
ZH 212	50	212	82
ZH 232	50	232	78
ZH 262	50	262	81
ZH 292	50	292	88
ZH 312	60	312	83

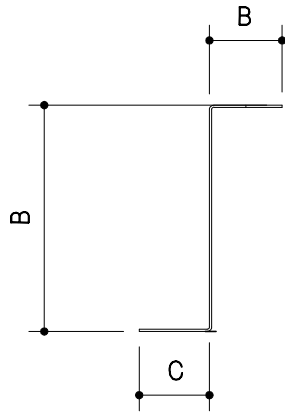



MARK:	No. RQD AS DRAWN:
MARK:	No. RQD OPP HAND:



Hi-SPAN Ltd.  
 Ayton Road, Wymondham  
 Norwich, Norfolk, NR18 0RD  
 Telephone: 01953 603081  
 Fax: 01953 607842  
 Email: technical@hi-span.com  
 Web: www.hi-span.com



DRG TITLE: ZED HANGER FABRICATION DETAIL

- NOTES:
- 1: ALL HOLES 18 DIA. U.N.O
  - 2: COUNTERFORMED HOLES IN WEB MARKED 
  - 3: COUNTERFORMED HOLES IN FLG MARKED 

DRAWN BY: DATE:

CHK'D BY: DATE:

DRG No: HW-004 Rev: ISSUE: 1st ISSUE

SECTION REF:

CUSTOMER:

ORDER REF:

SKETCH No:

HI-SPAN JOB No:

OVERALL LENGTH

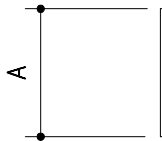

SECTION REF	DIMENSIONS A
B 50	50
B 100	100



MARK:	No. RQD AS DRAWN:
MARK:	No. RQD OPP HAND:



Hi-SPAN Ltd.  
 Ayton Road, Wymondham  
 Norwich, Norfolk, NR18 0RD  
 Telephone: 01953 603081  
 Fax: 01953 607842  
 Email: technical@hi-span.com  
 Web: www.hi-span.com



DRG TITLE: FLAT BRACE FABRICATION DETAIL

- NOTES:
- 1: ALL HOLES 18 DIA. U.N.O
  - 2: COUNTERFORMED HOLES IN WEB MARKED 
  - 3: COUNTERFORMED HOLES IN FLG MARKED 

DRAWN BY:	DATE:	CUSTOMER:
CHK'D BY:	DATE:	ORDER REF:
DRG No: HW-005	Rev:	ISSUE: 1st ISSUE
SECTION REF:	Hi-SPAN JOB No:	

STANDARD CLEATS		CLEAT REF.	
CLT 7015	150 mm LONG	CLT 7015	No. OFF
CLT 10015	150 mm LONG	CLT 10015	No. OFF
CLT 15015	150 mm LONG	CLT 15015	No. OFF
CLT 20016	150 mm LONG	CLT 20016	No. OFF
CLT 22516	150 mm LONG	CLT 22516	No. OFF
CLT 25516	150 mm LONG	CLT 25516	No. OFF
CLT 28516	150 mm LONG	CLT 28516	No. OFF
CLT 30516	150 mm LONG	CLT 30516	No. OFF

CONTINUOUS WALL CLEATS						
SECTION REF	DIMENSIONS					
	A	B	C	D	LENGTH	
CW 70	30	30	17		mm	No. OFF
CW 100	40	50	20		mm	No. OFF
CW 150	40	100	20		mm	No. OFF
CW 205	40	150	20		mm	No. OFF
CW 255	40	200	20		mm	No. OFF
CW 305	40	250	20		mm	No. OFF

CONTINUOUS WALL CLEATS							
SECTION REF	DIMENSIONS						
	E	F	G	K LENGTH	H LENGTH	J LENGTH	
AW 70	17	30	17	mm	mm	mm	No. OFF
AW 100	20	50	20	mm	mm	mm	No. OFF
AW 150	20	100	20	mm	mm	mm	No. OFF
AW 205	20	150	20	mm	mm	mm	No. OFF
AW 255	20	200	20	mm	mm	mm	No. OFF
AW 305	20	250	20	mm	mm	mm	No. OFF

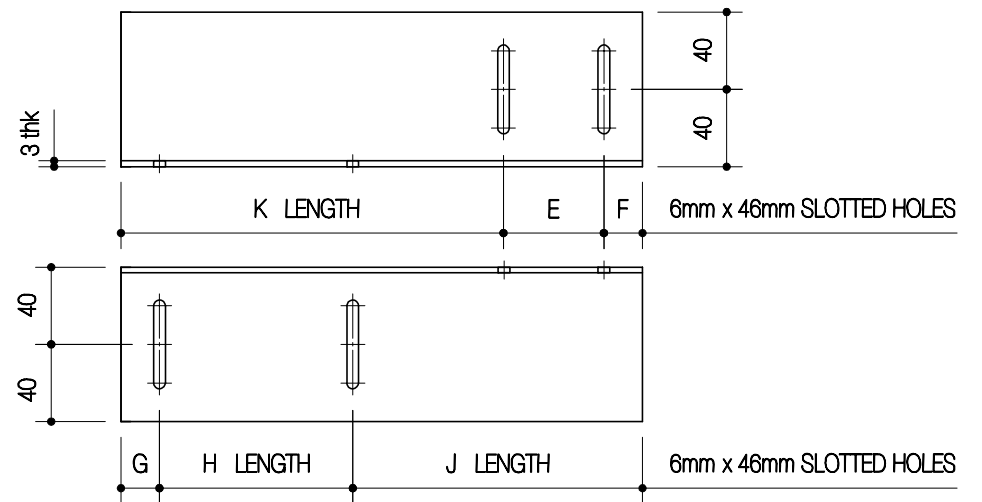
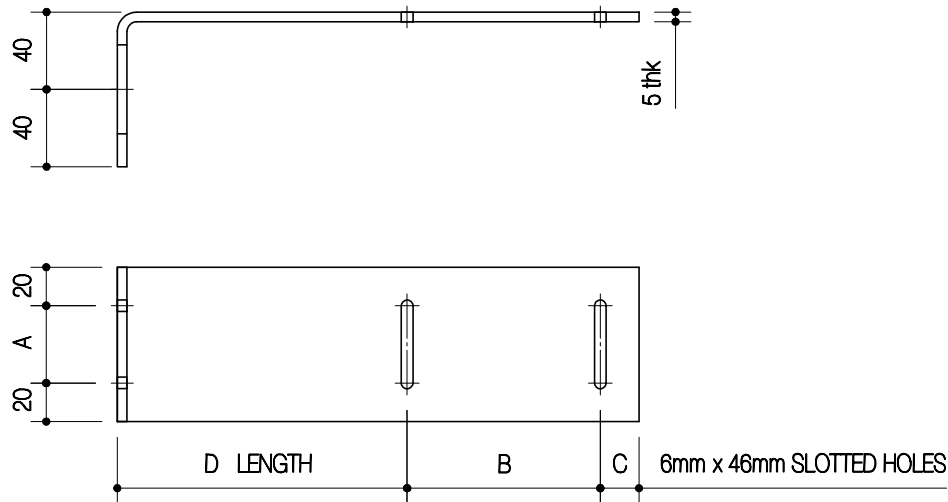

Hi-SPAN Ltd.  
 Ayton Road, Wymondham  
 Norwich, Norfolk, NR18 0RD  
 Telephone: 01953 603081  
 Fax: 01953 607842  
 Email: technical@hi-span.com  
 Web: www.hi-span.com



DRG TITLE: CLEATS - ORDER FORM

NOTES:

DRAWN BY:

DATE:

CHK'D BY:

DATE:

DRG No: HW-006

Rev:

ISSUE: 1st ISSUE

SECTION REF:

CUSTOMER:

ORDER REF:

SKETCH No:

Hi-SPAN JOB No:



EJOT FIXING REFERENCE	APPLICATION	
<b>STEEL TO CONCRETE</b>		
4H 6.3 x 32	FIXING 1.2mm - 4.0mm STEEL TO CONCRETE (5mm CONCRETE PILOT, 7mm STEEL PILOT)	No. OFF
4H 6.3 x 45		No. OFF
4H 6.3 x 67		No. OFF
<b>TIMBER TO STEEL</b>		
TS 6.3 x 32	FIXING 0.5mm - 1.2mm STEEL TO TIMBER (7mm PILOT REQUIRED)	No. OFF
TS 6.3 x 45		No. OFF
TS 6.3 x 60		No. OFF
<b>METAL (FINE THREAD)</b>		
HS 5.5 x 38	GENERAL STUD/TRK/BRACING, COMBINED THICKNESS 4.0mm - 12.5mm, HEX HEAD SCREW	No. OFF
HS 5.5 x 65		No. OFF
HS 5.5 x 65		No. OFF
HS 5.5 x 76		No. OFF
HS 5.5 x 100		No. OFF
HSCF 5.5 x 38		SAME AS ABOVE BUT LOW PROFILE HEAD
<b>METAL (COARSE THREAD)</b>		
JT - NH3-5.5 x 19	GENERAL STUD/TRK/BRACING, COMBINED THICKNESS UP TO 3.0mm, LOW PROFILE HEAD	No. OFF
JT2 - LH6-5.5 x 22	GENERAL STUD/TRK/BRACING, COMBINED THICKNESS UP TO 6.0mm, LOW PROFILE HEX HEAD	No. OFF
LSCF 5.5 x 25	GENERAL STUD/TRK/BRACING, COMBINED THICKNESS UP TO 3.0mm, LOW PROFILE HEAD	No. OFF
<b>BOARDING TO STEEL</b>		
WDHS 5.5 x 65	SINGLE LAYER PLASTERBOARD T STEEL STUDS 4 - 12 STEEL BUILD-UP, WAFER HEAD, WING TIP. CLAMPING CAPACITY DEPENDS ON LENGTH OF TEK.	No. OFF
WDHS 5.5 x 85		No. OFF
WDHS 5.5 x 119		No. OFF
WDLS 5.5 x 50	FIXING TIMBER TO STEEL STUDS 1.2mm - 3.0mm THK, CLAMPING CAPACITY DEPENDS ON LENGTH OF TEK	No. OFF
WDLS 5.5 x 65		No. OFF
WDLS 5.5 x 85		No. OFF
WDLS 5.5 x 100		No. OFF
WDLS 5.5 x 127		No. OFF
TBF 4.8 x 30		CHIPBOARD, PLY OR OSB BOARDING 18mm - 22mm THK TO 0.9mm - 3.0mm STEEL, WAFER HEAD, WING TIP.
TBF 4.8 x 45	No. OFF	
TBF 4.8 x 60	No. OFF	

EJOT FIXING REFERENCE	APPLICATION	
<b>DRILL ACCESSORIES</b>		
REISSER 5 x 110mm SDS DRILL BIT	MASONRY	No. OFF
5 x 60mm HSS DRILL BIT	STEEL	No. OFF
P2 DRIVE BIT STD	ALL P2 HEAD FIXINGS	No. OFF
P2 DRIVE BIT 50mm		No. OFF
P2 DRIVE BIT 100mm		No. OFF
P2 DRIVE BIT 150mm		No. OFF
P2 DRIVE BIT 200mm	HOLDS ALL STANDARD HEX DRIVE BITS	No. OFF
MAGNETIC BIT HOLDER 60mm		No. OFF
MAGNETIC BIT HOLDER 150mm	ALL EJOT HEX HEAD FIXINGS	No. OFF
8mm MAGNETIC HEX SOCKET		No. OFF
8mm MAGNETIC HEX SOCKET (cf)		No. OFF
M12 STUD x 160		No. OFF
RAWLPLUG RESIN CARTRIDGE		No. OFF
RAWLPLUG MIXER NOZZLES		No. OFF
RAWLPLUG MIXED GUN		No. OFF
HOLE CLEANING BRUSH		No. OFF
RAWL BLOW PUMP		No. OFF
14 Dia x 210 SDS MASONRY DRILL BIT		No. OFF
<b>BOLT SETS</b>		
M12 x 25 BZP	ALL BOLTS MUST BE ORDERED FROM A CE ACCREDITED COMPANY WITH FULL TRACEABILITY AND BOLTS MUST BE A MINIMUM GRADE 8.8 TO ISO STANDARDS	No. OFF
M12 x 30 BZP		No. OFF
M12 x 35 BZP		No. OFF
M12 x 40 BZP		No. OFF
M12 x 45 BZP		No. OFF
M12 x 50 BZP		No. OFF
M12 x 60 BZP		No. OFF
M12 x 65 BZP		No. OFF
M16 x 40 CSK BZP		No. OFF
M16 x 35 GALV		No. OFF
M20 x 60 BZP		No. OFF
M20 x 80 BZP		No. OFF
M20 x 100 BZP		No. OFF
M20 x 120 BZP		No. OFF



Hi-SPAN Ltd.  
Ayton Road, Wymondham  
Norwich, Norfolk, NR18 0RD  
Telephone: 01953 603081  
Fax: 01953 607842  
Email: technical@hi-span.com  
Web: www.hi-span.com



DRG TITLE: FIXINGS - ORDER FORM

NOTES:

DRAWN BY:

DATE:

CHK'D BY:

DATE:

DRG No: HW-007

Rev:

ISSUE: 1st ISSUE

SECTION REF:

CUSTOMER:

ORDER REF:

SKETCH No:

HI-SPAN JOB No: